



AERON



PC-07
Electric Heaters

INDEX

Fan Heaters, worth knowing	01
Electric Heater – Elektra - V	03
Technical specifications – Fan heater Elektra	04
ThermoWarm-Radiators	05
ThermoWarm-Radiators	06
Electric Heater – EVn	07



PORTABLE AND STATIONARY HEATERS

Air heating by means of fan heaters is a quick way of heating all types of premises such as sports halls, industrial premises, storage premises, etc. where quick heating is required. Fan heaters are also well suited for heating premises with high fire risk and agricultural storerooms. Portable fan heaters are particularly well suited for drying out buildings on building sites.

Air heating takes place through the air being forced past electrical heating elements by a fan and propelled into the room. In systems where fan heaters are only used for room heating and not for ventilation, the air circulates through the fan heaters repeatedly until the desired temperature has been achieved. A thermostat or a control unit in the room will switch the heating elements on and off in accordance with the required room air temperature.

If fan heaters are also used to ventilate a room, the electrical power required to heat a given quantity of air per time unit must be calculated and the size and number of fan heaters chosen on the basis of this calculation. When using air as a heat carrier, the thermal effect of rising hot air must be taken into consideration. Fan heaters are therefore best suited for use in relatively low-height rooms (below approx. 5 meters). If the ceiling height is more than approx. 5 meters, and it is not possible nor desirable to use ceiling-mounted fan heaters or radiant heating systems, air mixers should be installed to force down the hot air which accumulates below the ceiling.

AN INEXPENSIVE SOLUTION

Heating by means of fan heaters as an extremely inexpensive investment if the invested sum per installed kilowatt is calculated. The reason for this is that fan heaters often provide more power per appliance than, for example, radiant heating. Cabling is simpler as the appliances are mounted on a wall or are portable with connecting cables.

IMPORTANCE OF CORRECT DISTRIBUTION OF APPLIANCES

When installing fan heaters, it is important to distribute the appliances correctly. The greatest possible care must be taken to distribute the estimated heat output over as many appliances as possible. The reason for this is the desirability of evenness of temperature throughout the whole room, and as the temperature is highest near the air heaters, these must be spread out over the room. A number of fan heaters can be controlled from a common thermostat or control unit in the room.

FAN HEATERS AS A COMBINED HEATING AND VENTILATION SYSTEM

Stationary fan heaters can be fitted with a mixing unit for intake of outdoor air or mixing outdoor and indoor air. This is a simple way of supplying the room with heated outdoor air. The mixing unit is also available with simple, inexpensive automatic control which opens and closes the air damper via a clock in conjunction with the required indoor temperature.

REGULATION EQUIPMENT

In order for a hot-air system to function as intended in a quick and inexpensive way it is important to use the right regulating equipment.





A FAN HEATER FOR DEMANDING ENVIRONMENTS

Elektra is a serie of fan heaters for demanding environments. The compact Elektra is manufactured from stainless steel and is primarily intended for fixed installation. The brackets can be angled for portable use if required.

Elektra V is for use on ships and within the offshore industry, withstands vibrations and humidity. Approved by Det Norske Veritas.

- For fixed installation or portable use.
- Casing: stainless steel, Elektra C acid resistant. Grille and bracket: RAL 3020 (red).
- Output: 3, 6 kW.
- Elektra V has reinforced electrical insulation, motor and heating elements have a construction that absorbs vibrations. Available also for 440V/60Hz.
- Available in four versions for different demanding environments.

TECHNICAL SPECIFICATIONS – FAN HEATER ELEKTRA

Type	Output steps [kW]	Airflow [m³/h]	Voltage [V]	Amperage [A]	HxWxD [mm]	Weight [kg]
Elektra C. For corrosive environments						
ELC331	0/1/2/3	400	230V~	9/13,5	375x300x340	13
ELC633	0/1/3/6	1000	400V3~	4,5/8,9	445x375x430	20
ELC933	0/1/4.5/9	1000	230V3~	6,7/13,2	445x375x430	20
ELC1533	0/1/7.5/15	1300	400V3~	11,2/22	445x375x430	20
Elektra F. For rooms where there is a risk of fire						
ELF331	0/1/2/3	400	230V~	7/13,5	375x300x340	13
ELF633	0/1/3/6	700	400V3~	4,8/9,1	375x300x340	13
ELF933	0/1/4.5/9	1000	400V3~	6,7/13,2	445x375x430	20
Elektra V. For use on ships and within the offshore industry						
ELV331	0/1/2/3	400	230V~	9/13,5	375x300x340	13
ELV3333	0/1/1.5/3	400	400V3~	4,2/4,9	375x300x340	13
ELV3344	0/1/1.8/3.6	400	440V3~	4,7/5,3	375x300x340	13
ELV5333	0/1/2.5/5	700	400V3~	6,8/7,8	375x300x340	13
ELV6344	0/1/3/6	700	440V3~	7,4/8,5	375x300x340	13
Elektra H. For rooms with high temperatures						
ELH633	0/1/3/6	1000	400V3N~	4,5/8,9	445x375x430	20
ELH933	0/1/4.5/9	1000	400V3N~	6,7/13,2	445x375x430	20

Protection class Elektra V: IP44.

Approved by SEMKO and CE compliant. Elektra V is approved by Det Norske Veritas.

DIMENSIONS

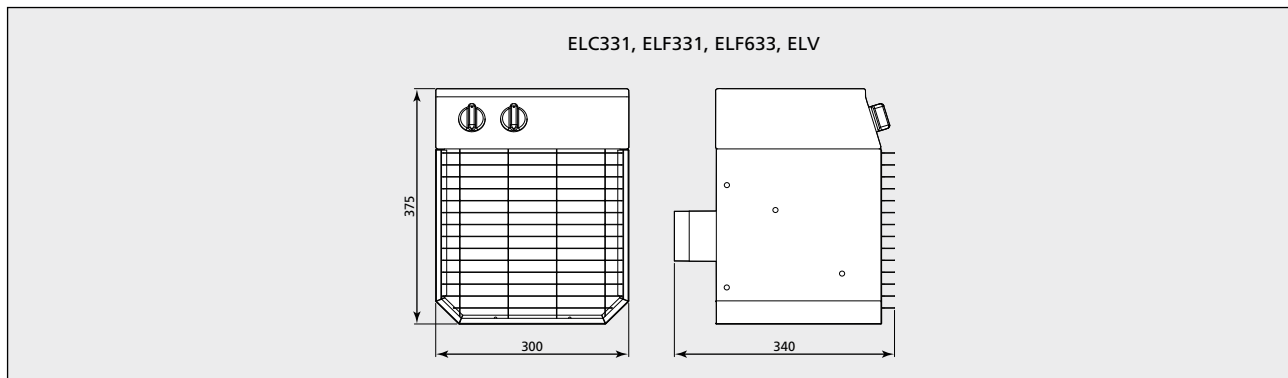

MOUNTING

Elektra is primarily intended for wall mounting, but the brackets can be angled for portable use.

The heat output is controlled by the built in thermostat (+5 – +35°C). Elektra H has a thermostat with setting range 0 – 70°C.

The on/off mode, and half or full heat output can be controlled with the output selector on the unit or with an external control panel mounted on to the wall for easy access.

ACCESSORIES

Type	Description
ELSRT	Control panel and thermostat, for ELC/ELV, start/stop
ELS	Control panel, for ELF, start/stop
ELRT	Thermostat, for ELH

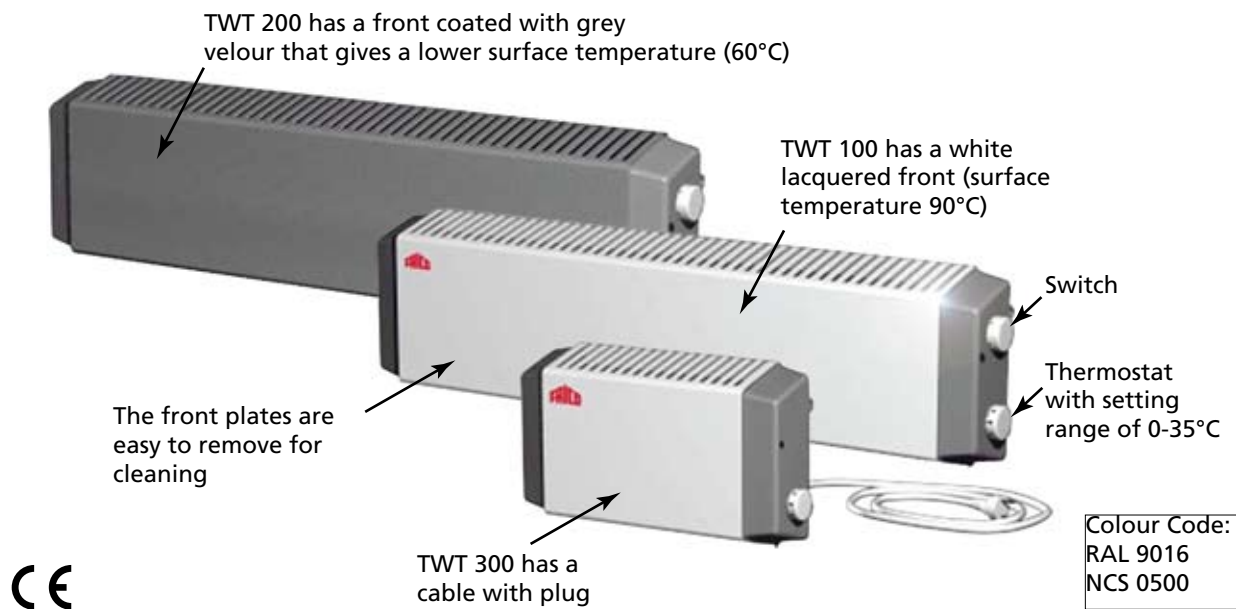

RIBBED FLANGE RADIATORS WITH ENCLOSED TUBE ELEMENTS: 300 - 1000 W

ThermoWarm is a series of very compact and easily positioned radiators. The ribbed flanges provide the radiators with a large heat-emitting surface. Thus, surface temperatures can be kept low, only 60 or alternatively 90 °C. All models have a thermostat with a setting range of 0 - 35 °C. TWT 100 and TWT 200 also have a switch, while the TWT 300 is equipped with a cable and plug.

WITH THERMOSTAT AND CURRENT SWITCH

Type		T33V	T53V	T53V
Output	W	300	500	1000
Surface temperature, max	°C	90	90	90
Weight	kg	1.5	2.0	3.0
Protection class		▲(IP 44)	▲(IP 44)	▲(IP 44)
Code 230 ~		TWT 10321	TWT 10521	TWT 11021
Code 400 ~		TWT 10331	TWT 10531	TWT 11031

WITH VELOUR-COATED FRONT, THERMOSTAT, AND CURRENT SWITCH

Type		T33V	T53V	T53V
Output	W	300	500	1000
Surface temperature, max	°C	60	60	60
Weight	kg	1.5	2.0	3.0
Protection class		▲(IP 44)	▲(IP 44)	▲(IP 44)
Code 230 ~		TWT 20321	TWT 20521	TWT 21021
Code 400 ~		TWT 20331	TWT 20531	TWT 21031

WITH CABLE, PLUG, AND THERMOSTAT (NO SWITCH)

Type		T33V	T53V	T53V
Output	W	300	500	1000
Surface temperature, max	°C	90	90	90
Weight	kg	1.5	2.0	3.0
Protection class		▲(IP 21)	▲(IP 21)	▲(IP 21)
Code 230 ~		TWT 30321	TWT 30521	TWT 31021

The ThermoWarm are approved by SEMKO and GOST. TWT 100, 230V is also approved by Det Norske Veritas.

THERMOWARM-RADIATORS

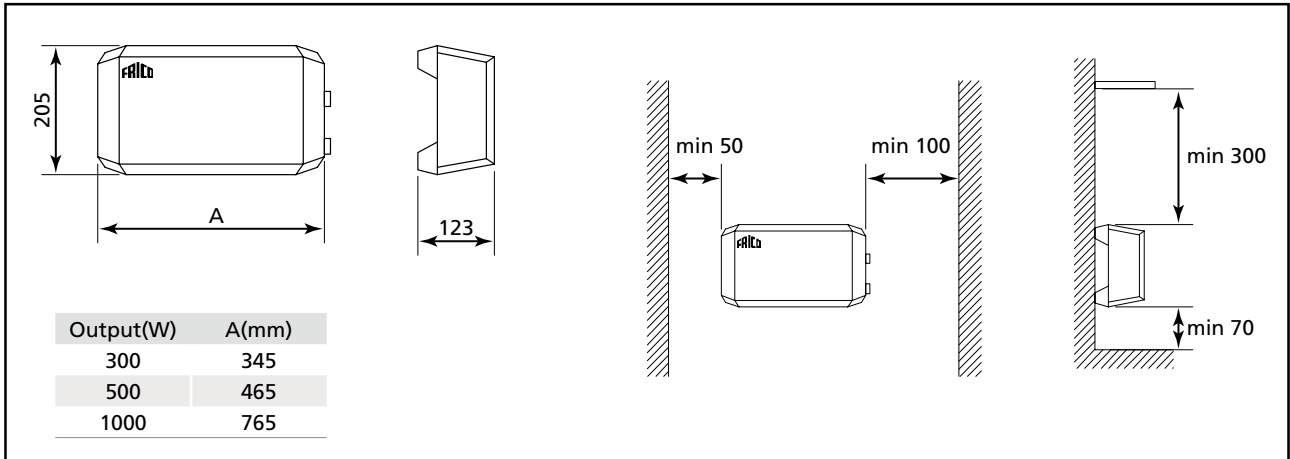

INSTALLATION

Minimum distances from the floor, walls, and window sills are given in the sketch above. The radiators are designed for permanent installation.



Thermo Navare EVN

ThermoNavare is a range of fan heaters approved by Det Norske Veritas for fixed installation in ships and mobile platforms, thought not on deck or in Ex-classified holds. The units have a built-in thermostat and operating switch. EVN is supplied with a robust wall bracket.

APPROVAL/AREA OF USE

The heaters are approved by Det Norske Vertias, certificate No. E-4834 for use on board ships and offshore units, tightness IP44.

El. nr.	Type	Power	Volt/fase	Regulation kW	Airflow m ³ /h	Weight kg	A	Δ t	m/s
4927710	EVN 3-23	3 kW	230/3	1,5 - 3,0	1300	15	7,5	6,7	3
4927711	EVN 6-23	6 kW	230/3	3,0 - 6,0	1300	18	15,0	13,4	3
4927712	EVN 9-23	9 kW	230/3	4,5 - 9,0	1300	19	22,5	20,0	3
4927713	EVN 3-40	3 kW	400/3	1,5 - 3,0	1300	15	4,3	6,7	3
4927714	EVN 6-40	6 kW	400/3	3,0 - 6,0	1300	18	8,6	13,4	3
4927715	EVN 9-40	9 kW	400/3	4,5 - 9,0	1300	19	13,0	20,0	3
4927716	EVN3-44	3 kW	440/3 60Hz	1,5 - 3,0	1500	17	3,95	5,8	3,5
4927717	EVN 6-44	6 kW	440/3 60Hz	3,0 - 6,0	1500	20	9,7	11,6	3,5
4927718	EVN 9-44	9 kW	440/3 60Hz	4,5 - 9,0	1500	21	11,8	17,4	3,5

ELECTRIC HEATER – EVN

PLACEMENT AND LOCATION

The EVN heater must be attached to the enclosed wall bracket with at least 4 pcs. M6 bolts for the bracket. All 6 screws to the cabinet must be used. Safety distance shown on sketch. must be followed.

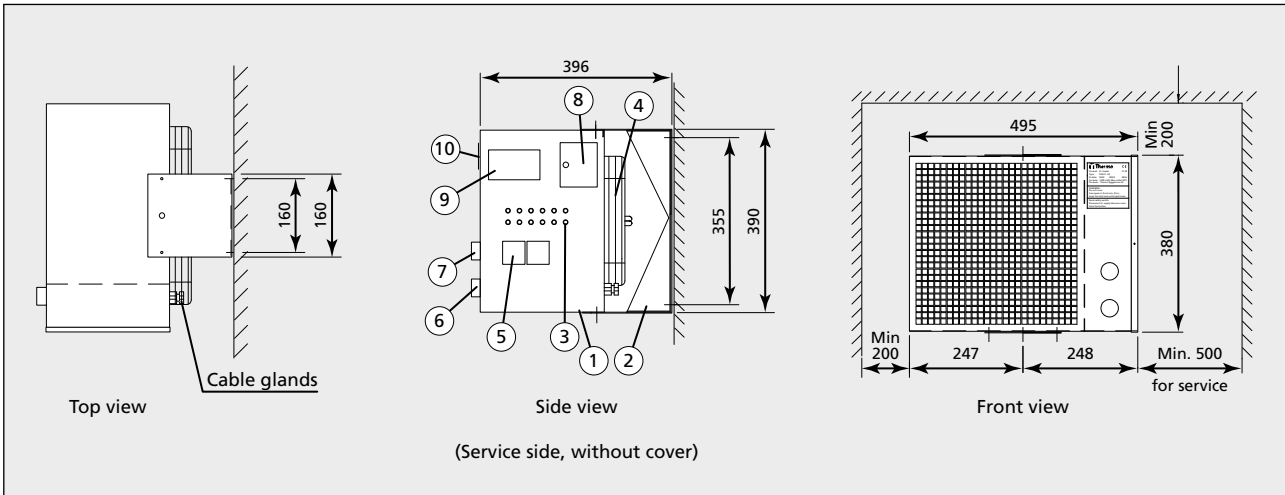

1. Cabinet
2. Wall bracket
3. Heating element
4. Fan with motor
5. Contractor
6. Thermostat – Prodigy
7. Regulation switch
8. Safety switch
9. Transformer
10. Name plate EVN

ELECTRICAL INSTALLATION

Electrical installations must be carried out by an authorised electrical contractor. Support cable and any extra cable for external thermostat and remote control switch may be of standard marine type. Make sure that the screws in terminal are properly tightened on both sides. Check for correct function of the fan and the two groups. Operate the regulation switch and the thermostat.

The cover must be properly secured.

MAINTENANCE

Regular maintenance is normally not necessary.

Thick layers of dust on the surface of the heater constitute a fire hazard.

Check the inlet and outlet grids for dirt, and clean with pressure air.

REPAIRS

Repairs must only be carried out by an authorised electrical contractor.

When ordering spare parts, it is important to specify the correct type of heater, output and voltage, as well as the production date and description of the spare part.

SPARE PARTS

You will find this described in the wiring diagram inside the cover.