



**AERON**



*PC-10  
Air Valves and Ventilation Grilles*

Control Valve KSU .....	01
Bayonet Socket KKT .....	03
Control Valve NE .....	05
Bayonet Socket VG .....	07
Ventilation Grille standard - RMT .....	09
RMT - Accessories & RMT - Fixing Systems.....	10
RMT - Pressure Loss and Sound Level.....	11
Ventilation Grille Standard.....	10
CMT - Fixing Systems.....	11
CMT - Pressure Loss and Sound Power Level .....	12
CMT - Throw Effect .....	13
Steel Grille, Circular Duct- RGS .....	14



## Control Calve KSU



## Dimension

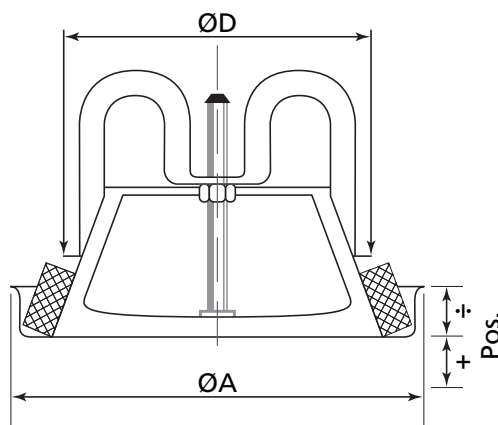

### DESCRIPTION

The KSU valve is used for air exhaust. The valve has a low sound effect level even at a relatively large pressure loss. KSU is supplied in four standard sizes: 100, 125, 160 and 200 mm. The KSU valve fits directly into Lindab pipes by means of a standard VG type bayonet fitting or VGU or VGM type valve bushing.

ØD mm	A mm	m kg
100	134	0,30
125	160	0,40
160	191	0,60
200	241	0,80

### MATERIALS AND FINISH

Material: Galvanised steel  
 Standard finish: Powder-coated  
 Standard colour: White RAL 9010, gloss 30

### Ordering: **KSU aaa**

Type \_\_\_\_\_  
 Size \_\_\_\_\_

# CONTROL VALVE KSU

## Specifications

### PERFORMANCE

The volume flow  $q$  (l/s, m<sup>3</sup>/h), total pressure loss  $p_t$  (Pa) and sound pressure level  $L_A$  (dB(A)) are shown in the diagrams at various cone settings.

### PRESSURE LOSS $P_t$

The diagram shows the pressure loss  $p_t$  (Pa) specified as total pressure loss.

### SOUND PRESSURE LEVEL $L_A$

The diagram show the sound pressure level  $L_A$  (dB(A)) at room attenuation of 4 db.

### SOUND POWER LEVEL $L_W$

Sound power level  $LW$  (dB) =  $L_A + K_{ok}$ . See table 1.

Table 1 - Mean frequency (Hz)

Size	63	125	250	500	1K	2K	4K	8K
100	-	-4	-1	1	-3	-1	-6	
125	-	-1	0	-1	-3	0	-8	
160	-	-1	0	3	0	-7	-9	
200	-	2	1	1	0	-5	-6	

tolerance +/-6 +/-3 +/-2 +/-2 +/-2 +/-2 +/-3

### SOUND ATTENUATION $\Delta L$

Sound attenuation  $\Delta L$  (dB) of unit including end reflection to the inlet diameter. See table 2.

Table 2 - Mean frequency Hz

Size	63	125	250	500	1K	2K	4K	8K
100	-	18	14	12	12	14	5	-
125	-	17	12	11	12	11	7	-
160	-	14	12	11	11	14	5	-
200	-	13	11	11	13	12	7	-

tolerance +/-6 +/-3 +/-2 +/-2 +/-2 +/-2 +/-3

### BALANCING

Balancing data of the control of the air flow is available in a separate brochure.

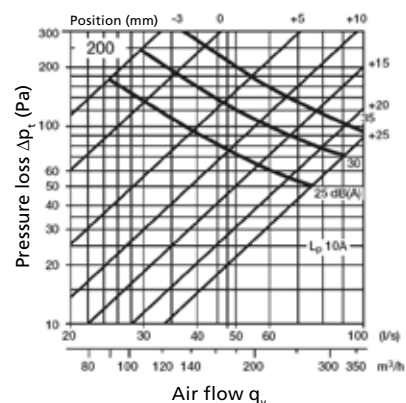
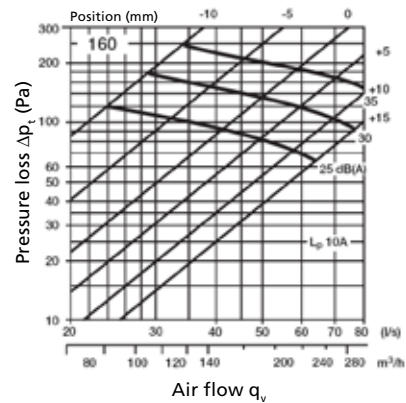
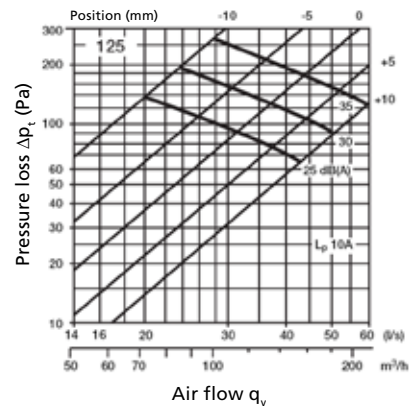
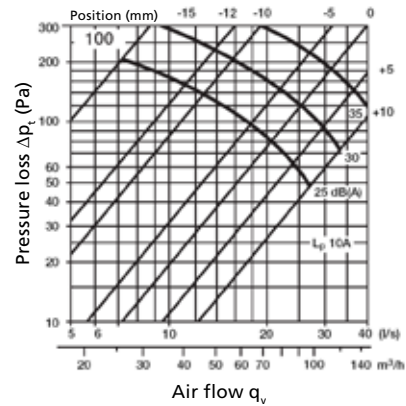

# BAYONET SOCKET KKT



## Control Calve KSU

## Dimension

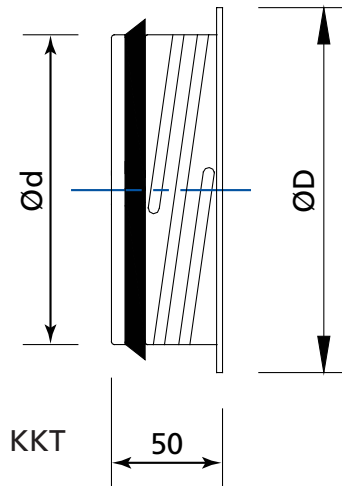

### DESCRIPTION

The tight mounting ring KKT are designed for use with circular supply and exhaust valves in order to give a complete solution for various mounting options with circular spiral and flexible ducts. The Veloduct gasket of KKT guarantees a tight installation.

### PRODUCT FACTS

Mounting rings KKT  
 Fast and easy mounting  
 Manufactured from steel sheet.  
 Model KKT is supplied with rubber gasket  
 Product code example:  
 Mounting ring KKT-160

Size	Ød	ØD	Ød <sub>s</sub>	ØD <sub>s</sub>	Weight g	Pack size
80	79	105	-	-	80	75
100	99	125	100	98	100	50
125	124	150	125	123	120	40
150	149	175	150	148	180	25
160	159	185	160	158	190	25
200	199	225	200	198	240	20

### PRODUCT CODE

Mounting ring with rubber seal KKT-aaa

Size \_\_\_\_\_  
 080, 100, 125, 150, 160, 200

# BAYONET SOCKET KKT

## CONSTRUCTION

The mounting ring is made of steel sheet employing the draw press technique. Model KKT is supplied with rubber gasket.

The VELODUCT rubber gasket and the method of mounting in soft material are patented.

## INSTALLATION

KKT and KKL are designed for fast and easy mounting both with spiral and fl exible ducting.

Mounting rings KKT are easy to install with rivets or screws into the duct. The gasket of KKT guarantees a tight installation of the ring in a circular duct.

The ring can be fastened to the surrounding material with screws which go through the openings in the ring fl ange.

When installing the ring in a suspended ceiling which is soft, bend up the tongues of the ring fl ange and press them inside the ceiling material (see fi g. 2). Flexible duct can then be secured with suitable clamps (see fi g. 3).

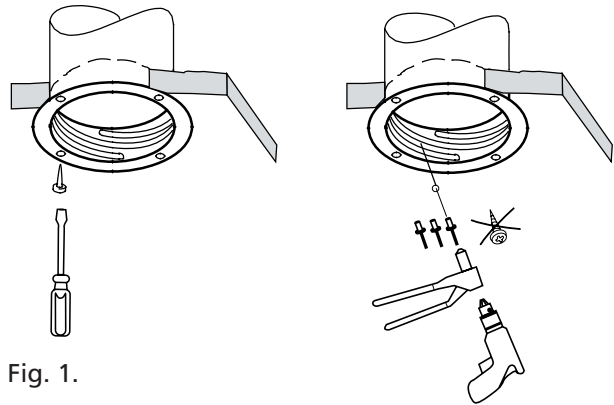

Fig. 1.

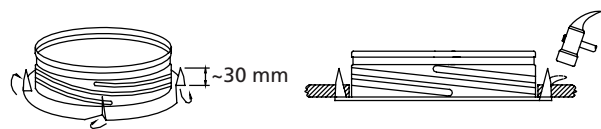

Fig. 2.

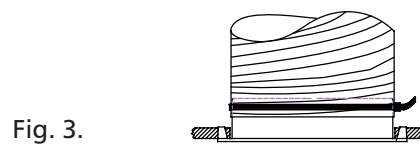

Fig. 3.

# CONTROL VALVE NE



## Control Valve NE



## Dimension

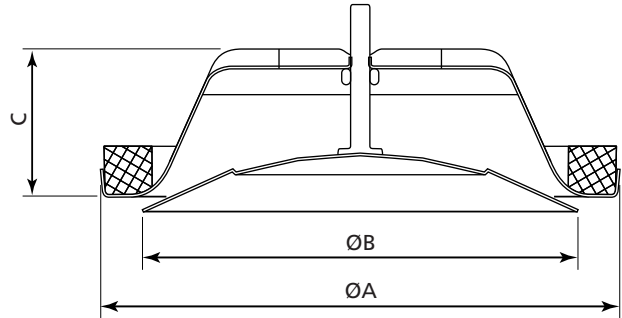

### PRODUCT FACTS

NE Supply air valve  
 Supply air valve intended for installation in the ceiling.  
 Manufactured from steel sheet.  
 Six sizes.  
 Product code example:  
 Supply air valve NE-100  
 Mounting ring KKT-100

NE	A	B	C	Weight, g
80	112	93	37	140
100	132	110	40	190
125	162	135	46	260
150	193	158	54	370
160	193	158	54	370
200	245	205	64	550

### CONSTRUCTION

The NE supply air valve is manufactured from steel sheet painted white. Other paint finishes are available to special order. Valve body has a gasket made of cellular plastic and the control disc with screw spindle enables easy regulation and positional locking.

Mounting rings VG are manufactured from galvanized steel sheet.

### INSTALLATION

Mounting ring VG is fitted into the duct with screws or rivets. The valve is fixed by "a screwing action" to locate the valve lugs into indents in the mounting ring.

Regulation and measurement of air flow Regulation of air flow is achieved by turning the control disc to change adjustment dimension  $s$ (mm). The measurement of air flow is made by a pressure difference measurement with a separate measuring tube. Refer to separate air flow measurement diagrams for information.

### QUICK-SELECTION

Valve Size	Air flow l/s (m <sup>3</sup> /h) at sound level		
	25 db	30 db	35 db
NE-80	12	14 (50)	17
NE-100	19	23 (83)	27
NE-125	38	45 (162)	52
NE-150	47	57 (205)	65
NE-160	47	55 (198)	63
NE-200	70	85 (306)	100

**Ordering:** VG aaa  
 Type \_\_\_\_\_  
 Size \_\_\_\_\_

# CONTROL VALVE NE

## Specifications

### SOUND POWER LEVEL $L_W$

NE	Correction $K_{oct}$ in dB						
	NE octave bands, middle frequency, Hz						
	125	250	500	1000	2000	4000	8000
80	7	6	3	-2	-11	-23	-35
100	6	6	3	-2	-10	-21	-33
125	6	8	2	-3	-10	-21	-33
150	9	9	2	-5	-12	-22	-33
160	10	9	1	-5	-10	-22	-32
200	9	9	2	-4	-12	-20	-32
Tolerance $\pm$	3	2	2	2	2	2	3

Sound power levels by octave bands are obtained by adding to total sound pressure level  $L_{p10A}$ , dB(A) the corrections  $K_{oct}$  presented in the table above according to the following formula:

$$L_{W_{oct}} = L_{p10A} + K_{oct}$$

Correction  $K_{oct}$  is average value in range of use of NE unit.

NE	Slot s(mm)	Sound attenuation $\Delta L$ (dB)							
		octave bands, middle frequency, Hz							
		63	125	250	500	1000	2000	4000	8000
80	2	26	20	15	14	11	8	10	9
	6	24	19	13	11	8	5	8	6
	12	24	19	13	10	6	4	5	6
100	2	22	19	14	12	11	12	10	12
	6	22	17	11	9	8	9	6	9
	12	22	17	11	8	6	7	4	7
125	3	20	17	12	11	9	9	8	8
	7	19	15	10	8	7	7	5	5
	12	19	15	9	7	5	5	4	4
150	4	19	14	10	9	9	9	7	8
	12	18	13	8	7	6	5	5	5
	20	18	13	8	5	5	4	5	5
160	4	18	14	10	10	10	10	8	8
	9	18	13	9	8	7	7	6	6
	20	18	13	8	7	6	5	5	5
200	5	17	13	10	9	11	10	9	9
	9	16	12	8	8	9	9	8	7
	20	15	11	7	6	7	6	7	6
Tol. $\pm$		6	3	2	2	2	2	2	3

The average sound attenuation  $\Delta L$  from duct to room including the end reflection of the connecting duct in ceiling installation, is obtained in the table above.

### Definitions

$q_v$	air volume	l/s
$\Delta p_t$	total pressure drop	Pa
$L_{p10A}$	sound pressure level with 4 dB room attenuation 10 m <sup>2</sup> sab	dB(A)
$L_{W_{oct}}$	sound power level by octave bands	dB
$\Delta L$	sound attenuation	dB
$K_{oct}$	correction	dB

NE-100

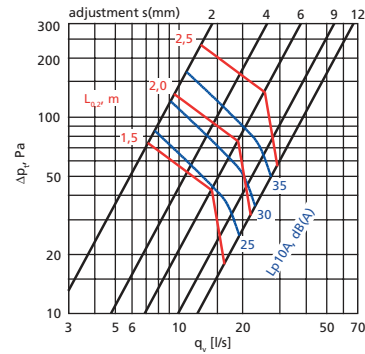

NE-125

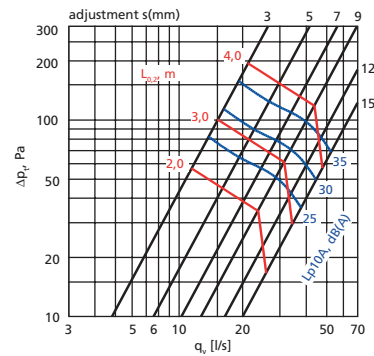

NE-160

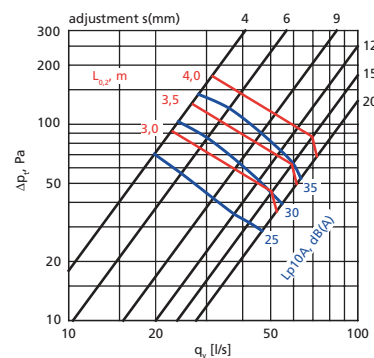

NE-200

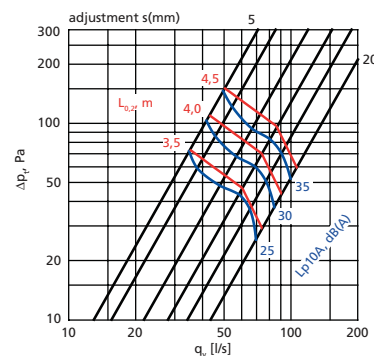

# BAYONET SOCKET VG



## Bayonet Socket VG



## Dimension

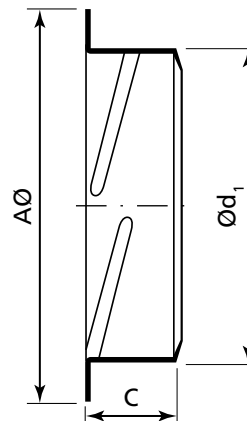

### DESCRIPTION

Bayonet socket that fits direct into Lindab SR ducts. There are four standard sizes of VG socket (100, 125, 160 and 200mm).

Ød <sub>1</sub> mm	ØA mm	C mm	m kg
100	127	30	0,05
125	155	30	0,07
160	186	30	0,10
200	230	30	0,14

### Ordering:

Type ———— **VG**  
Size ———— **aaa**



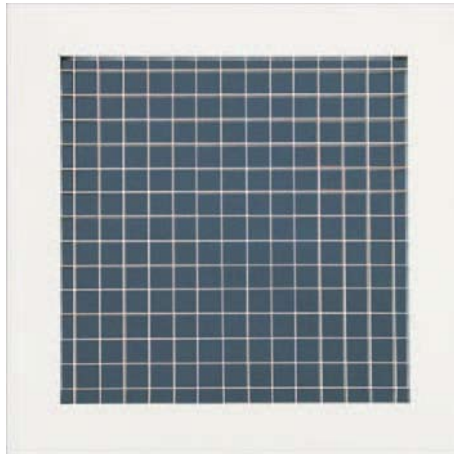

## RMT EGGCRATE GRILLES

The RMT-A series grilles are designed to be used in airconditioning, ventilation, and heating.

They form a square netting, designed to be used in extraction.

They are mounted on walls or in false ceilings.

## RMT -CLASSIFICATION

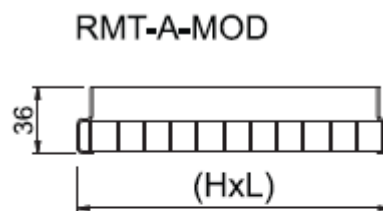
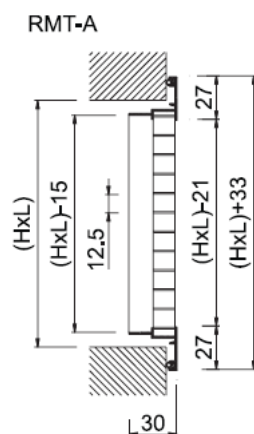

DMT-AR-MOD	EMT-AR-MOD
595x295	595x1195
595x595	
1195x595	

RMT-A Square netting grille of 12,7x12,7 mm.

When assembly with metallic frame, measures H and L increase 8 mm

RMT-A-MOD Grille specially designed to replace a 600x600 false ceiling tile.

### MATERIAL

Frame in extruded aluminium and netting in strips of laminated aluminium.

All the grilles are provided with a seal on the back of the frame in order that the perimeter in contact with walls, ceiling, ducts, etc... is airtight.

# RMT - ACCESSORIES & RMT - FIXING SYSTEMS



## Additional Accessories

RMT-A+SP

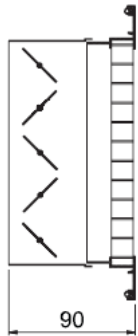

SP Opposed blades damper to regulate the air flow.

The damper is held in place by an easily accessible key inside the grille.

It is entirely constructed from milled aluminium.

The damper is held in place by "S" springs.

RMT-A+PFT

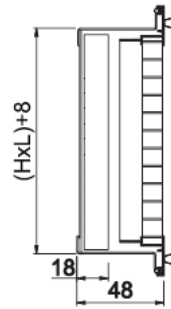

PFT Filter box made of galvanised steel, with mesh and filter included (K/8 efficiency EN 779 G3).

The grille is held in place by threaded knobs.

RMT-A-MOD+SP

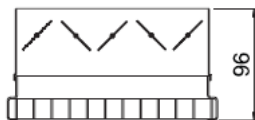

RMT-A-MOD+PFT

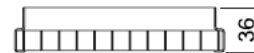

RMT-A-MOD+PFT Grille and filter box made of galvanised steel, with mesh and filter included (K/8 efficiency EN 779 G3).

## Fixing Systems



(S)

(S) The grille is fixed in place with clips (standard supply).

It requires the CM mounting frame.

When assembling with the metallic frame, measures H and L increase 8 mm.

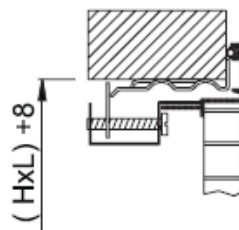

(O)

(O) The grille is fixed in place by a hidden screw.

It requires the CM mounting frame. When assembling with metallic frame, measures H and L increase 8 mm.

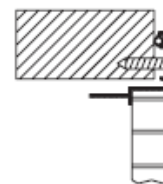

(T)

(T) The grille fixed in place with screws.

Designed to replace a 600x600 false ceiling tile (standard for MOD versions).

### FINISHES

AA Anodised in matt silver.

RAL... Lacquer in other colours (RAL specifications).

# RMT - PRESSURE LOSS AND SOUND LEVEL



## RMT SERIES

FREE FACE AREA m<sup>2</sup>.

H \ L	150	200	250	300	350	400	450	500	600
100	0,009	0,013	0,017	0,021	0,025	0,028	0,032	0,036	0,043
150	0,016	0,022	0,028	0,034	0,040	0,046	0,052	0,058	0,070
200	0,022	0,030	0,038	0,047	0,055	0,064	0,072	0,080	0,097
250	0,028	0,038	0,049	0,06	0,071	0,081	0,092	0,103	0,124
300	0,034	0,047	0,060	0,073	0,086	0,099	0,112	0,125	0,151
350	0,040	0,055	0,071	0,086	0,101	0,117	0,132	0,147	0,178
400	0,046	0,064	0,081	0,099	0,117	0,134	0,152	0,169	0,205
450	0,052	0,072	0,092	0,112	0,132	0,152	0,172	0,192	0,232
500	0,058	0,080	0,103	0,125	0,147	0,169	0,192	0,214	0,258
600	0,070	0,097	0,124	0,151	0,178	0,205	0,231	0,258	0,312

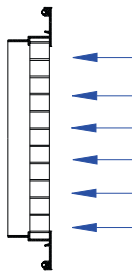

RECOMMENDED VELOCITY.

Vmin m/s	Vmax m/s
2	3

Determination of air flow.  
Measuring the Vf in different points  
of the grille, we find the Vfmed.

$$Q \text{ (l/s)} = V_{fmed} \text{ (m/s)} * A_{free} \text{ (m}^2) * 1000$$

$$Q \text{ (m}^3\text{/h)} = V_{fmed} \text{ (m/s)} * A_{free} \text{ (m}^2) * 3600$$

CORRECTION FACTOR FOR Lwa1.

Lwa1(kf)	-9	-6	-3	-	+4	+7
Afree m <sup>2</sup>	0,01	0,02	0,05	0,1	0,2	0,4

Weighted noise level related to  
Afree = 0,1m<sup>2</sup>.

$$Lwa = Lwa1 + Kf$$

FREE VELOCITY, PRESSURE LOSS AND SOUND POWER LEVEL.

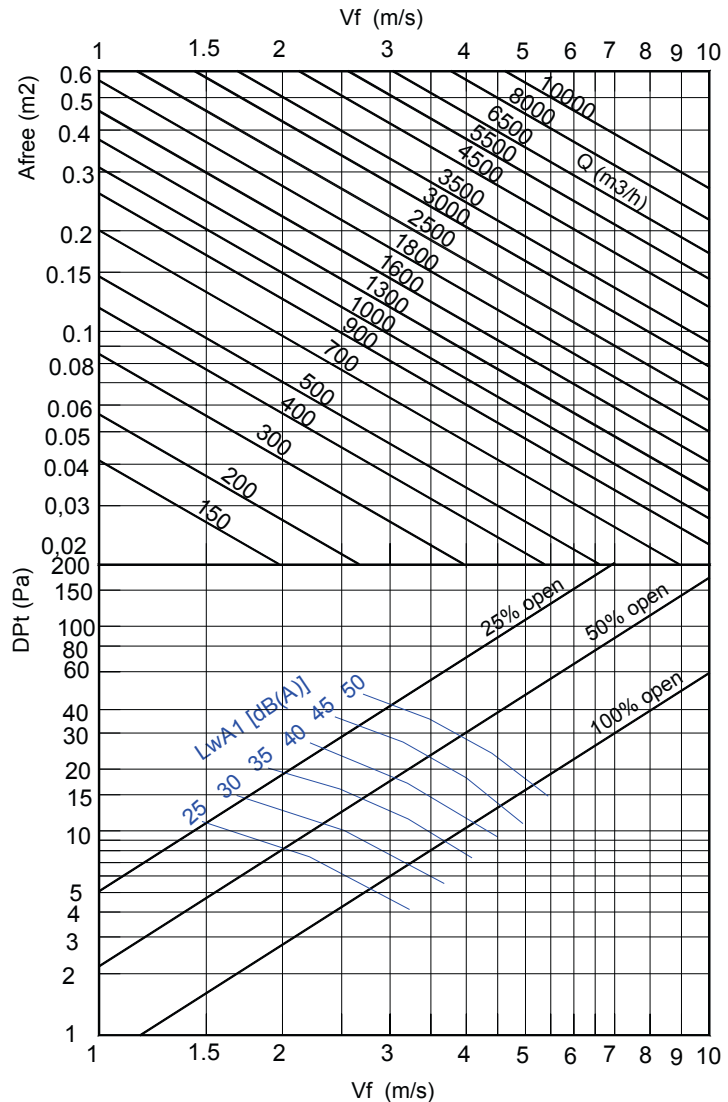

# VENTILATION GRILLE STANDARD

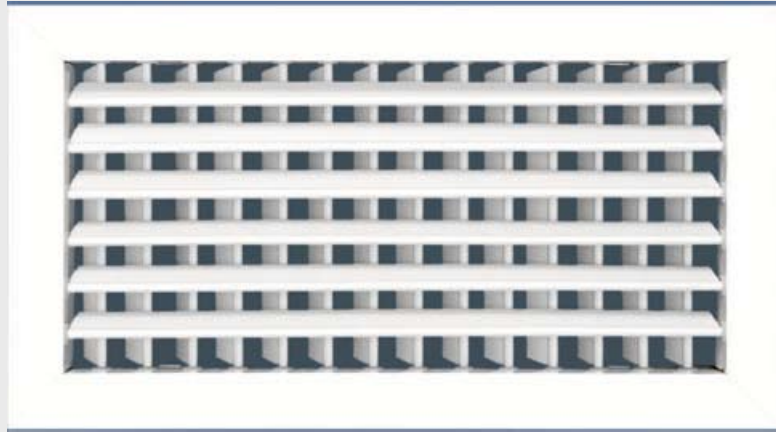

## CMT DOUBLE DEFLECTION GRILLES

The CTM series grilles are designed to be used in air-conditioning, ventilation and heating.

They are mounted on walls or in false ceilings.

The direction of the blades can be altered, making it possible to graduate the extent, the height and the width of the air stream.

## CMT - CLASSIFICATION

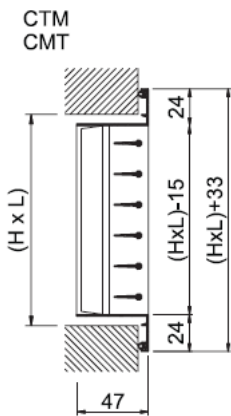

CTM Double deflection grilles with moveable blades parallel to the longer side in front and parallel to the shorter side rear.

CMT Double deflection grilles with moveable blades parallel to the shorter side in front and parallel to the longer side rear.

## CMT - ADDITIONAL ACCESSORIES

CMT+SP

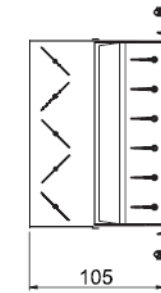

SP Opposed blades damper to regulate the air flow. The damper is operated by an easily accessible key inside the grille. It is entirely constructed from milled aluminium. The damper is held in place by "S" springs.

SPM-C Operated by means of an external key.

CMT-FD

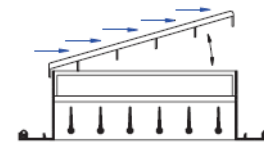

FD Flap damper with inclined moveable control.

Constructed in galvanised steel with black enamel.

## MATERIAL

CTM-AN Extruded aluminium grilles.

CTM-N Galvanised steel grilles.

All grilles are provided with seal on the back of the frame in order that the perimeter in contact with walls, ceiling, ducts, etc... is airtight.



## Fixing Systems

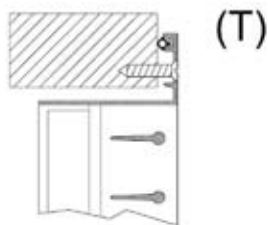

(T)

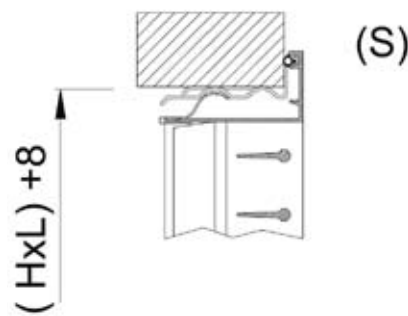

(S)

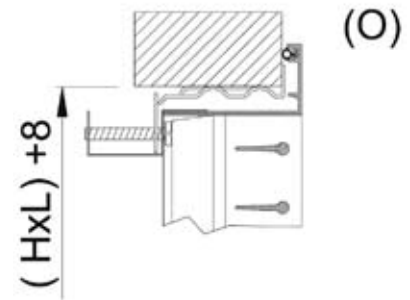

(O)

(T) The grille is fixed in place with screws.

(S) The grille is fixed in place with screws.

(O) The grille is fixed in place by a hidden screw.

It requires the CM mounting frame. When assembling with metallic frame, measures H and L increase 8 mm.

It requires the CM mounting frame. When assembling with metallic frame, measures H and L increase 8 mm.

## Finishes

Aluminium Grilles:  
AA Anodised in matt silver..

M9016 Lacquer in white colour similar to RAL 9016.

RAL... Lacquer in other colours (RAL specifications).

Steel Grilles:  
M9006 Lacquer in metallic grey colour, similar to RAL 9006.

R9010 Lacquer in white colour RAL 9010.

RAL... Lacquer in other colours (RAL specifications).

# CMT - PRESSURE LOSS AND SOUND POWER LEVEL

## CTM SERIES

FREE FACE AREA m2.

H \ L	150	200	250	300	350	400	450	500	600	700	800	900	1000
100	0,008	0,012	0,015	0,018	0,022	0,025	0,028	0,031	0,037	0,044	0,051	0,057	0,063
150	0,013	0,019	0,024	0,029	0,034	0,037	0,044	0,049	0,060	0,070	0,080	0,090	0,101
200	0,018	0,026	0,033	0,040	0,047	0,054	0,061	0,068	0,082	0,096	0,110	0,124	0,138
250	0,024	0,033	0,042	0,051	0,059	0,056	0,077	0,086	0,104	0,122	0,140	0,159	0,175
300	0,029	0,040	0,050	0,062	0,072	0,083	0,094	0,105	0,126	0,148	0,169	0,191	0,213
350	0,034	0,047	0,059	0,072	0,085	0,098	0,110	0,123	0,148	0,174	0,199	0,225	0,250
400	0,039	0,054	0,058	0,083	0,098	0,112	0,127	0,142	0,171	0,200	0,229	0,258	0,287
450	0,044	0,061	0,077	0,094	0,110	0,127	0,143	0,160	0,193	0,226	0,259	0,292	0,325
500	0,049	0,068	0,086	0,105	0,123	0,142	0,160	0,178	0,215	0,252	0,289	0,325	0,362
600	0,059	0,082	0,104	0,126	0,149	0,171	0,193	0,215	0,259	0,304	0,348	0,393	0,438

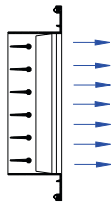

RECOMMENDED VELOCITY.

Vmin m/s	Vmax m/s
2	3.5

Determination of air flow.

Measuring the Vf in different points of the grille, we find the Vfmed.

$$Q \text{ (l/s)} = V_{\text{fmed}} \text{ (m/s)} * A_{\text{free}} \text{ (m}^2\text{)} * 1000$$

$$Q \text{ (m}^3\text{/h)} = V_{\text{fmed}} \text{ (m/s)} * A_{\text{free}} \text{ (m}^2\text{)} * 3600$$

CORRECTION FACTOR FOR Lwa1.

Afree m2	0,01	0,02	0,05	0,1	0,2	0,4
Lwa1(kf)	-9	-6	-3	-	+4	+7

Weighted noise level related to Afree = 0,1m2.

$$L_{\text{wa}} = L_{\text{wa1}} + K_{\text{f}}$$

CORRECTION FACTOR OF PRESSURE LOSS FOR

	0°	22°	45°
Kp	1	1,28	1,5

$$DPT' = Dpt * K_p$$

FREE VELOCITY, PRESSURE LOSS AND SOUND POWER LEVEL.

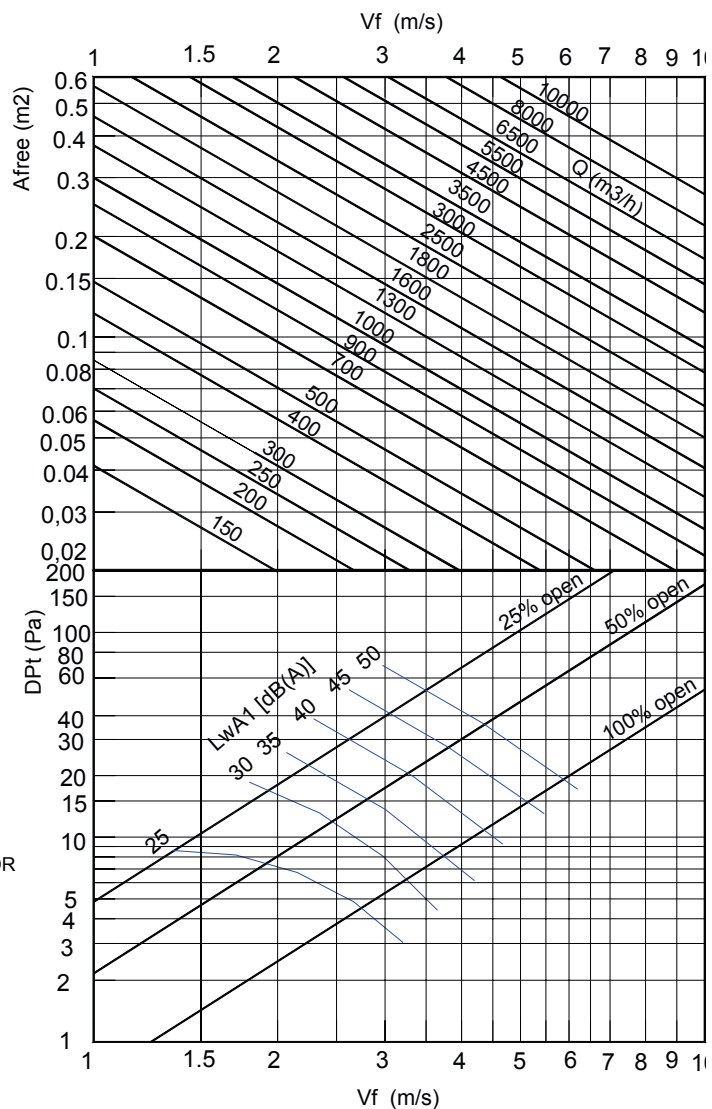



# STEEL GRILLE, CIRCULAR DUCT- RGS

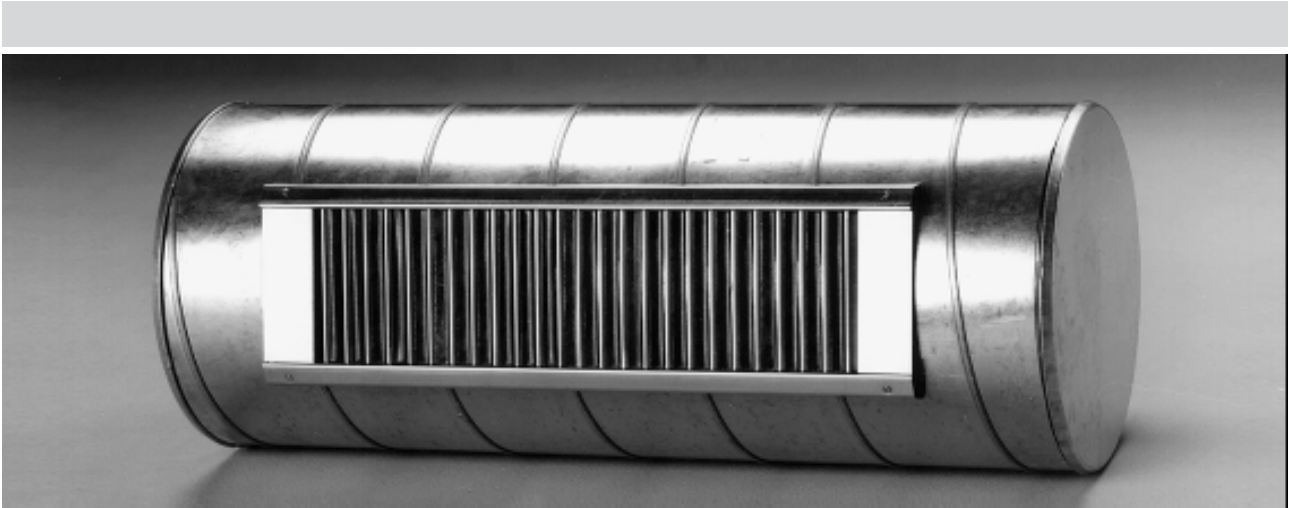

## Description

The RGS is a ventilation grille with vertical, adjustable bars for direct mounting in circular ducts.

The grille is designed in such a way that its flanges always seal tightly against the duct, regardless of the duct diameter.

The RGS is made of hot-galvanised sheet steel, and is assembled without the use of welding. This means that it can be used without further surface treatment, and that it has the same surface finish as the duct on which it is mounted.

The grille can be supplied with horizontal deflection bars, a straight or inclined hit and miss damper, and a blade damper.

## MATERIALS AND FINISH:

Grille:	Hot-galvanised steel
Hit and miss damper:	Electro-galvanised steel
Blade damper:	Electro-galvanised steel

The grille can be supplied powder-coated.

## Ordering:

	<b>RGS</b>	<b>a</b>	<b>bbb</b>	<b>ccc</b>
Type	_____	_____	_____	_____
Accessories	_____	_____	_____	_____
A dimension	_____	_____	_____	_____
B dimension	_____	_____	_____	_____

## Description

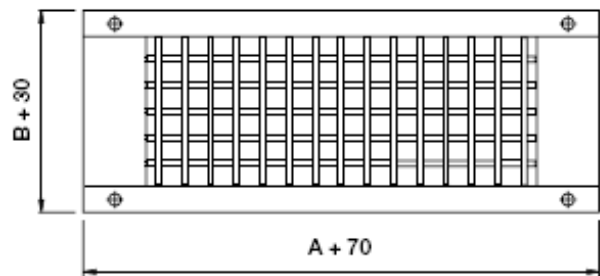

Screws enclosed

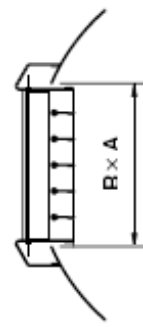
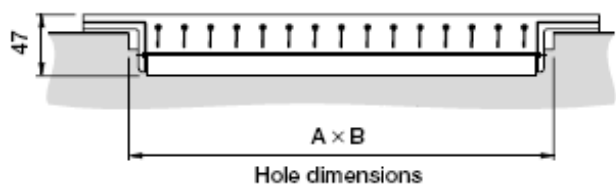



## Dimensions

Dimension A x B	Min. duct dimension	Free area m <sup>2</sup>	C-dimension mm	Weight RGS-1 kg
325 x 75	160	0.017	106	1.1
425 x 75	160	0.023	116	1.4
525 x 75	160	0.028	126	1.7
625 x 75	160	0.034	131	1.9
825 x 75	160	0.045	151	2.4
1025 x 75	160	0.056	166	2.9
1225 x 75	160	0.068	186	3.2
325 x 125	250	0.028	106	1.3
425 x 125	250	0.037	116	1.8
525 x 125	250	0.047	126	2.0
625 x 125	250	0.056	131	2.4
825 x 125	250	0.074	151	3.1
1025 x 125	250	0.093	166	3.4
1225 x 125	250	0.112	186	4.0
325 x 150	315	0.034	106	1.4
425 x 150	315	0.045	116	1.9
525 x 150	315	0.056	126	2.3
625 x 150	315	0.068	131	2.6
825 x 150	315	0.093	151	3.5
1025 x 150	315	0.112	166	3.9
1225 x 150	315	0.136	186	4.4
325 x 225	500	0.056	106	2.2
425 x 225	500	0.074	116	3.0
525 x 225	500	0.093	126	3.4
625 x 225	500	0.112	131	3.7
825 x 225	500	0.148	151	5.1
1025 x 225	500	0.186	166	5.8
1225 x 225	500	0.224	186	6.3

## APPLICATION

### RGS-2

Suited for both supply and exhaust air. The grille is equipped with a single balancing damper, and has a lower sound level than RGS-6.

### RGS-3

Like RGS-2, but with horizontal guide bars suitable for supply air in particular.

### RGS-4

Only suitable for exhaust air. Inclined hit and miss damper.

### RGS-6

Suitable for supply and exhaust air. Supplied with an inclined hit and miss damper, which means that air is distributed evenly all over the grille.

### RGS-7

Like RGS-6, but with horizontal guide bars suitable for supply air in particular.

## Accessories

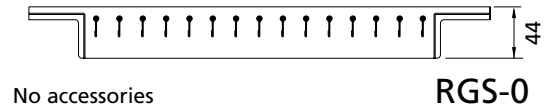

No accessories

RGS-0

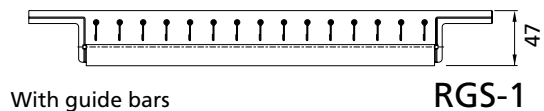

With guide bars

RGS-1

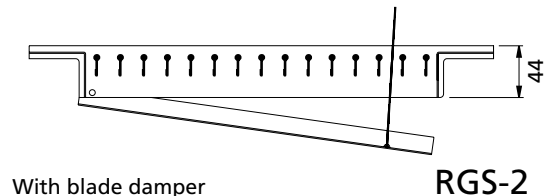

With blade damper

RGS-2

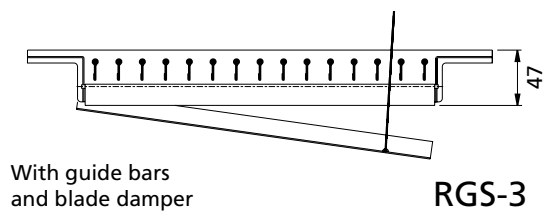

With guide bars  
and blade damper

RGS-3

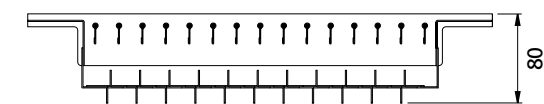

With straight hit and miss damper

RGS-4

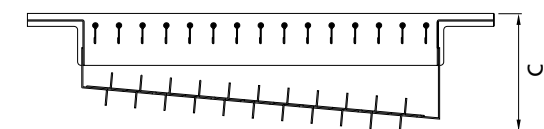

With inclined hit and miss damper

RGS-6

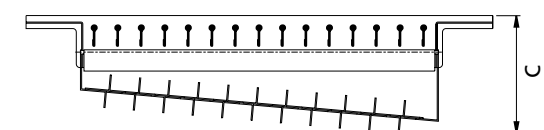

With guide bars and inclined  
hit and miss damper

RGS-7