



AERON



***PC-11
Galley Ventilation***

INDEX

KVF - Kitchen Canopy with supply Air	01
KVF - Kitchen Canopy with supply Air	02
Dimensions (mm).....	03
Dimensions (mm).....	04
Dimensions (mm).....	05
Specifications.....	06
Kro Grease Filter.....	07
Kro Grease Filter.....	08
Capacity and Dimensions.....	09
Diagram	10



The KVF kitchen ventilation canopy is an advanced ventilation solution that helps to provide a comfortable, clean and hygienic environment within today's modern commercial catering facility.

The highly efficient KVF canopy includes Halton's Capture Jet™ technology, which allows the canopy to operate with up to 30% lower exhaust flows than traditional hoods. This utilizes the higher entrainment efficiency of a faster, compact Capture air jet to maximize the induction of room air into the canopy at the critical front face area, reducing the amount of air that normally 'spills' out into the kitchen and onto the chefs below.

- Halton's Capture Jet™ technology, reduces the exhaust air flow volume required and increases the capture and containment efficiency of the canopy, while reducing energy use.
- Draft free air distribution directly into the working zone from the front face, low velocity supply diffuser.
- High efficiency grease filtration using Halton's KSA 'Multi-cyclone' filters – up to 95% removal of particles at a size of 8 microns or above – *UL and **NSF classified.
- Individually adjustable 'personal' supply nozzles located within the front supply plenum – help to reduce the effects of the radiant heat given off by the cooking equipment.
- Supplied as standard with lighting, balancing dampers on both supply and exhaust air connections and T.A.B.™ testing and balancing taps which allow accurate and simple balancing and commissioning of the airflows.
- Stainless steel, welded construction (AISI 304).

L	Recommended Exhaust air volumes- HF=330 (std KSA filter)		Recommended Supply air volumes	
	l / s	m ³ /h	H = 555 mm	H = 400 mm
1500	235...447	846...1610	100...200 l/s / meter length or 360...720 m ³ /h / meter length LpA < 50 dB(A)	80...150 l/s / meter length or 288...540 m ³ /h / meter length LpA < 50 dB(A)
2000	310...580	1116...2088		
2500	420...770	1512...2772		
3000	460...860	1656...3096		

Exhaust air volumes indicated above are for a recommended pressure loss of KSA filter between 35...120 Pa - LpA < 56 dB(A)

* UL= Underwriters Laboratories (UL is an independent organization founded by the insurance industry in the U.S.A, giving approvals to safety tested products).

** NSF= National Sanitation Foundation (promoting hygiene and sanitation in the U.S.A)

KVF - KITCHEN CANOPY WITH SUPPLY AIR

FUNCTION

The canopy positioned above the cooking equipment collects the warm air and contaminants (A). The capture jets (B) direct the air towards the KSA grease filters (C) where the impurities and grease particles are separated from the exhaust air using the cyclone separation principle. Grease and contaminants that have been removed flow into a drain channel and towards the collection tap/tray (D). Make up air is distributed at low velocity into the space through the front face of the canopy (E), the throw pattern of this air can be adjusted using the knob positioned inside the canopy. Individual supply nozzles (F) are adjustable to produce increased velocities in the working zone near the cooking equipment, which helps to reduce the effect of the radiant heat given off by the cooking equipment.

CONSTRUCTION

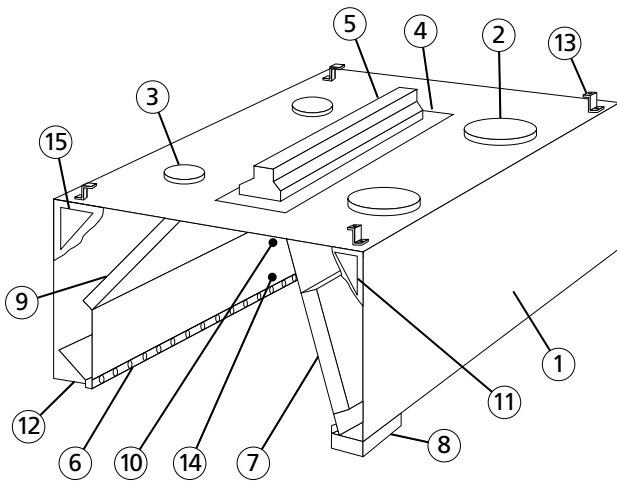

The KVF canopy comprises of a supply air module, light fixture, damper plates, airflow measurement taps and KSA grease filters.

Joints on the lower edge of the canopy are of fully welded construction to avoid the harmful dripping of water onto the cooking equipment below.

DIMENSIONS

Length	1000...3000
Width	1000...1700 2000...3400 for Island model-Two sections 2000...2400 for Island model-One section
Height	555, 400

Contact your local Halton office or representative for special requirements.

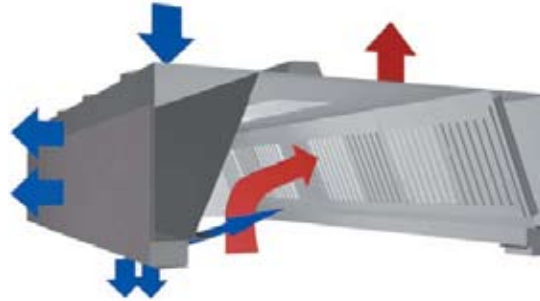

COMPUTATIONAL FLUID DYNAMICS: CFD

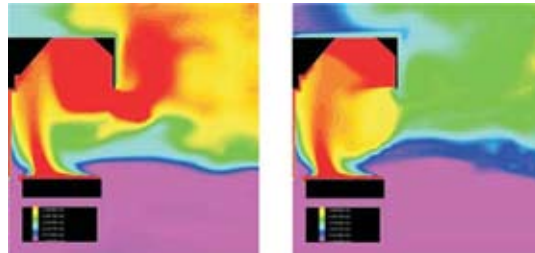

- 1 Outer casing – visible parts in stainless steel AISI 304
- 2 Exhaust air connection and damper plate
- 3 Supply air connection and damper plate
- 4 Installation hatch
- 5 Light fixture
- 6 Capture Jets nozzles
- 7 KSA grease filters
- 8 Grease collection tray or drain tap
- 9 Thermal insulation
- 10 Adjustment wires for capture air
- 11 General Exhaust (GE) with damper plate (optional)
- 12 Personal supply air nozzle
- 13 Hanging brackets
- 14 Adjustment of supply airflow pattern
- 15 General Supply (GS) (optional)

Grease and dirt removed by the filters can be removed from the canopy by either a drain tap or by emptying the collection tray.

The supply air chamber is thermally insulated to prevent condensation on the inner face above the cooking equipment.

ACCESSORIES- refer to ACCESSORIES section

- General exhaust (GE) / General supply (GS)
- Cover Boards – where canopies are below ceiling level
- Infill Panels
- KSA grease filters
- Blind filter in stainless steel
- Integrated light fixture -IP65 (high T°)
- Surface mounted light – IP65 (Maxi. ambient T°: 35°C)
- Non-standard spigots sizes and position
- Canopy cut outs to fit around columns
- Exhaust/supply roof in stainless steel

DIMENSIONS (MM)



KVD – 1-WALL MODEL

L	1000.....3000
B	1000.....3000
H	555, 400
D1	250
D2	315
G	220
C	180

Note: dimensions above are for modular section only; larger canopies are assembled using a combination of separate modules, which makes transportation and site handling easier.

LIGHT

A	115
P	190
F	190
E	390(B<1100), 490(B>1100)
I	680 (L<1400, 2x18w), 1285 (L•1400, 2x36w)

LOCATION OF CONNECTIONS (MM)

For typical sizes

L	M	Exhaust		Supply		
		2x315	1x315	2x250	3x250	3x250
		K	J	K	J	K
1500	375	750	L/2	750	-	-
2000	500	1000	L/2	1000	L/2	1500
2500	500	1500	L/2	1500	L/2	1500
3000	500	2000	L/2	2000	L/2	2000

WEIGHT (KG)

400 mm				
L/B	1100	1300	1500	1700
1500	68	73	78	83
2000	83	88	93	99
2500	96	101	116	123
3000	110	116	145	153

500 mm				
L/B	1100	1300	1500	1700
1500	73	78	83	88
2000	90	95	100	106
2500	105	112	118	125
3000	120	129	139	147

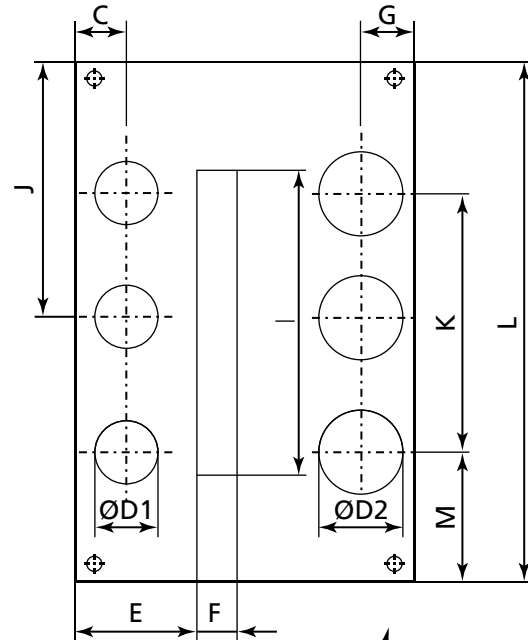

Mounting bracket
150 mm high

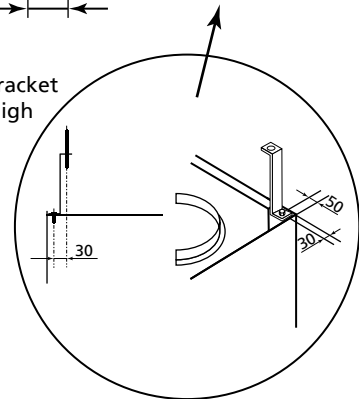

POSITION OF DRAIN TAP, WHEN FITTED.

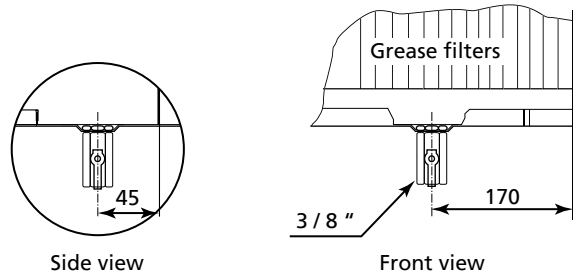

DIMENSIONS (MM)

KVF - 2

ISLAND MODEL - TWO SECTIONS

L	1000.....3000
B	1000.....3000
H	555, 400
D1	250
D2	315
G	220
C	180

Note: dimensions above are for modular section only; larger canopies are assembled using a combination of separate modules, which makes transportation and site handling easier.

LIGHT

A	115
P	190
F	190
E	390(B<1100), 490(B>1100)
I	680 (L<1400, 2x18w), 1285 (L•1400, 2x36w)

LOCATION OF CONNECTIONS (MM)

For typical sizes

		Exhaust		Supply		
		2x (2x315)	2x (1x315)	2x (2x250)	2x (3x250)	2x (3x250)
L	M	K	J	K	J	K
1500	375	750	L/2	750	-	-
2000	500	1000	L/2	1000	L/2	1500
2500	500	1500	L/2	1500	L/2	1500
3000	500	2000	L/2	2000	L/2	2000

WEIGHT (KG)

400 mm					
L/B	2200	2600	3000	3400	
1500	136	146	156	166	
2000	166	176	186	198	
2500	192	202	232	246	
3000	220	232	290	306	

500 mm					
L/B	2200	2600	3000	3400	
1500	46	156	166	176	
2000	180	190	200	212	
2500	210	224	236	250	
3000	240	258	278	294	

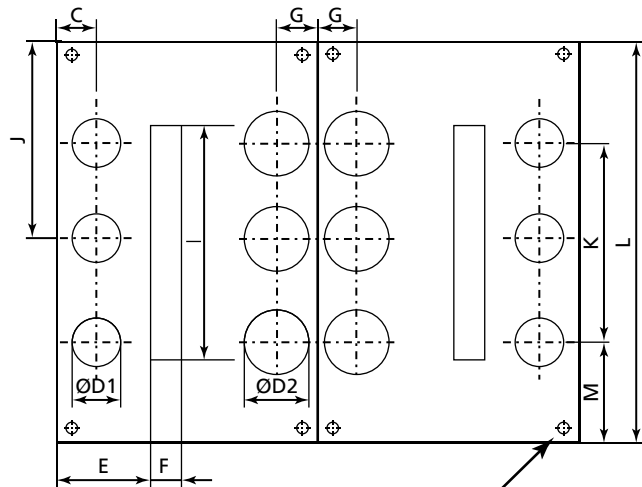
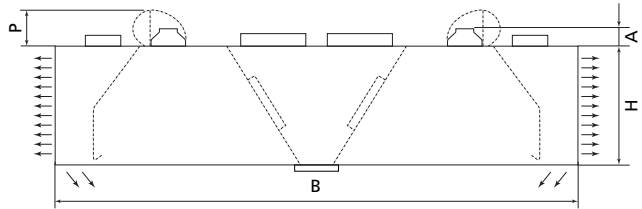

Mounting bracket
150 mm high

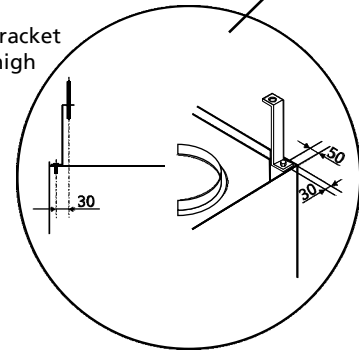

POSITION OF DRAIN TAP, WHEN FITTED.

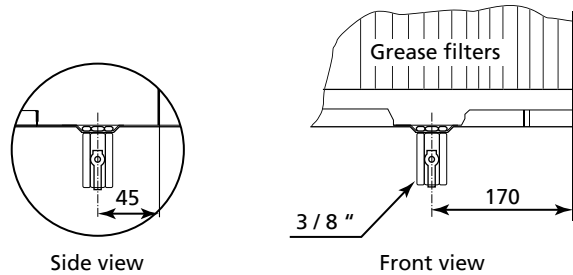

DIMENSIONS (MM)



KVF – M

ISLAND MODEL - ONE SECTIONS

L	1000.....2500
B	1000.....2400
H	555, 400
D1	250
D2	315
G	440
C	180

Note: dimensions above are for modular section only; larger canopies are assembled using a combination of separate modules, which makes transportation and site handling easier.

LIGHT

A	115
P	190
F	190
E	390(B<1100), 490(B>1100)
I	680 (L<1400, 2x18w), 1285 (L•1400, 2x36w)

LOCATION OF CONNECTIONS (MM)

For typical sizes

		Exhaust		Supply		
		2x (2x315)	2x (1x315)	2x (2x250)	2x (3x250)	2x (3x250)
L	M	K	J	K	J	K
1500	375	750	L/2	750	-	-
2000	500	1000	L/2	1000	L/2	1000
2500	500	1500	L/2	1500	L/2	1500

WEIGHT (KG)

400 mm			
L/B	2000	2200	2400
1500	114	124	134
2000	144	154	164
2500	170	180	190

500 mm			
L/B	2000	2200	2400
1500	124	134	144
2000	158	168	170
2500	188	198	208

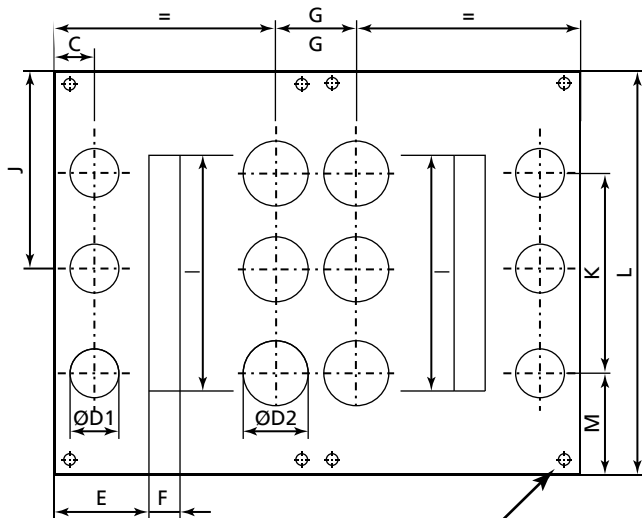
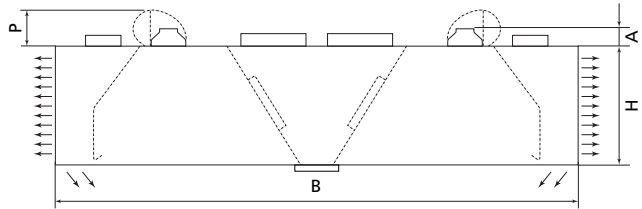

Mounting bracket
150 mm high

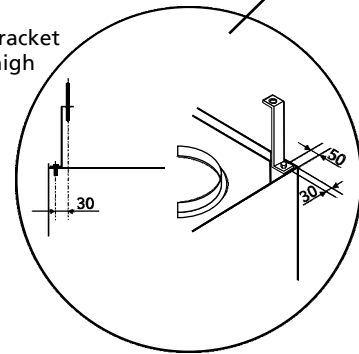

POSITION OF DRAIN TAP, WHEN FITTED.

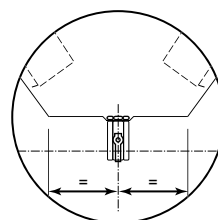

Side view

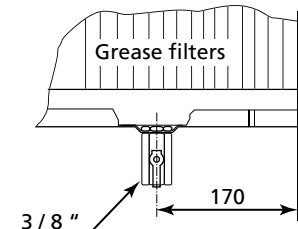

Front view

SPECIFICATIONS

General: The manufacture of all Halton kitchen canopies is to be controlled by an ISO9000 registered quality system, constructed from stainless steel to material specification AISI 304.

The kitchen canopies shall be supplied complete with outer casing/main body, supply air plenum, pressure measurement taps, supply and extract air spigot connections with damper plates, installation hatch, fluorescent light fixture, Capture Jets™ nozzles, grease filters, perimeter drain channel, drain tap or collection tray, adjustment wires for supply air and hanging brackets.

Outer casing/Main body: Outer casing panels shall be constructed of stainless steel sheet to AISI 304 in brushed satin finish. Each joint shall be spot-welded, riveted or machine stitched. The canopy shall be provided with a full perimeter condense channel and crush folded sloping edges, which are properly deburred. The joint of lower edge are fully welded, avoiding harmful dripping of water.

Supply Plenum Area: The supply air plenum shall be insulated with M0 sealed glass wool slab of density 95Kg/m³ and shall be provided with access by removal of main casing perforated stainless steel front panels.

A rotating knob shall be located within the canopy for the adjustment of the air throw pattern.

The plenum roof panels (supply and exhaust) shall be constructed of galvanized steel.

Personal Supply Air Nozzles: The supply air nozzles shall be constructed from ABS plastic and shall be adjustable to provide directional airflow.

Capture jet: The hood shall be designed with capture jet technology (Halton patented), to reduce the exhaust air flow volume required and increases the capture and containment efficiency of the canopy, while reducing energy use.

Pressure Measurement Taps: The pressure measurement taps shall be located on the inside canopy for supply and extract airside.

Grease Filters: The grease filters shall be supplied in modular size 500 x 330 x 50mm and shall be removable via two folding handles

The grease filters shall be constructed from stainless steel to AISI 304 and shall be NSF and UL classified. High grease filter efficiency is achieved by a unique form (Halton patented) of honeycomb filter, which causes a spiraling of the airflow inside the honeycomb.

Spigot Connections: The spigot connections for supply and extract air shall be constructed from galvanized steel and shall be supplied with a sealing gasket and airflow balancing damper plate manufactured from galvanized steel. The supply air damper shall be adjustable via high tensile stranded wire cables

Fluorescent Light Fixture: Each canopy shall be provided with fluorescent light fixture to provide approximately 500 lux at the cooking appliances work surface. The light fixture shall be suitable for single phase 230 V supply and shall be constructed to protection standard IP65. The light fittings shall be hinged to allow access to canopy roof.

3x1 mm² core electrical cable connecting the light fitting to the conduit box containing multiple connectors shall be provided.

Access Hatch: Each canopy shall be provided with an access hatch stainless steel AISI 304 with plain mill finish, surrounded by a tempered glass light diffuser. Heat tolerance of glass shall be -40 to +300° C. The hatch shall be hinged and held in position with screws.



KRO GREASE FILTER

- Polished filter house of stainless steel.
- Cells made of stainless steel frame and aluminium interior.
- Simple installation.
- Attractive appearance.
- Reduces fire danger.
- For large and small kitchens.
- Delivered in 20 standard models.
- Recommended for ships and offshore.
- Norwegian production.
- Protected design.

KRO GREASE FILTER

KRO Grease filter will prevent grease and other particles from clinging to ducts, fans, grilles etc.

- KRO Grease filter is delivered with a filter house made of polished stainless steel plates (AISI 430)
- Types V, AB and AO are delivered with loose drip pans as a standard.
- The cells are made of stainless steel frames and have a filter medium made of aluminium.
- The cells are held in place by springs, which give good tightening against the filter house.
- The cells have 2 handles for easy removal when cleaning.

TYPES

Type V

- Delivered with 2, 4 or 6 cells (V1, V2, V3)
- Size of cells are 50/50 or 50/25
- Central mounting with exhaust on top of the filter.

Type AB

- Delivered with 1, 2 or 3 cells (AB1, AB2, AB3)
- Size of cells are 50/50 or 50/25
- Wall mounting with exhaust behind the filter.

Type AO

- Delivered with 1, 2 or 3 cells (AO1, AO2, AO3)
- Size of cells are 50/50 or 50/25
- Wall mounting with exhaust on top of the filter.

Type F

- Delivered with 1 cell
- Size of cells are 50/50 or 50/25
- Central mounting with exhaust on top of the filter.

MAINTENANCE

The cells can be cleaned by using steam, hosing with warm water, washing in a washing machine or they can be placed in warm soap water over night.

It is important that the cells be cleaned often and that one, perhaps, has reserve cells.

Each and every filter is followed by own maintenance instructions.

CAPACITY AND DIMENSIONS

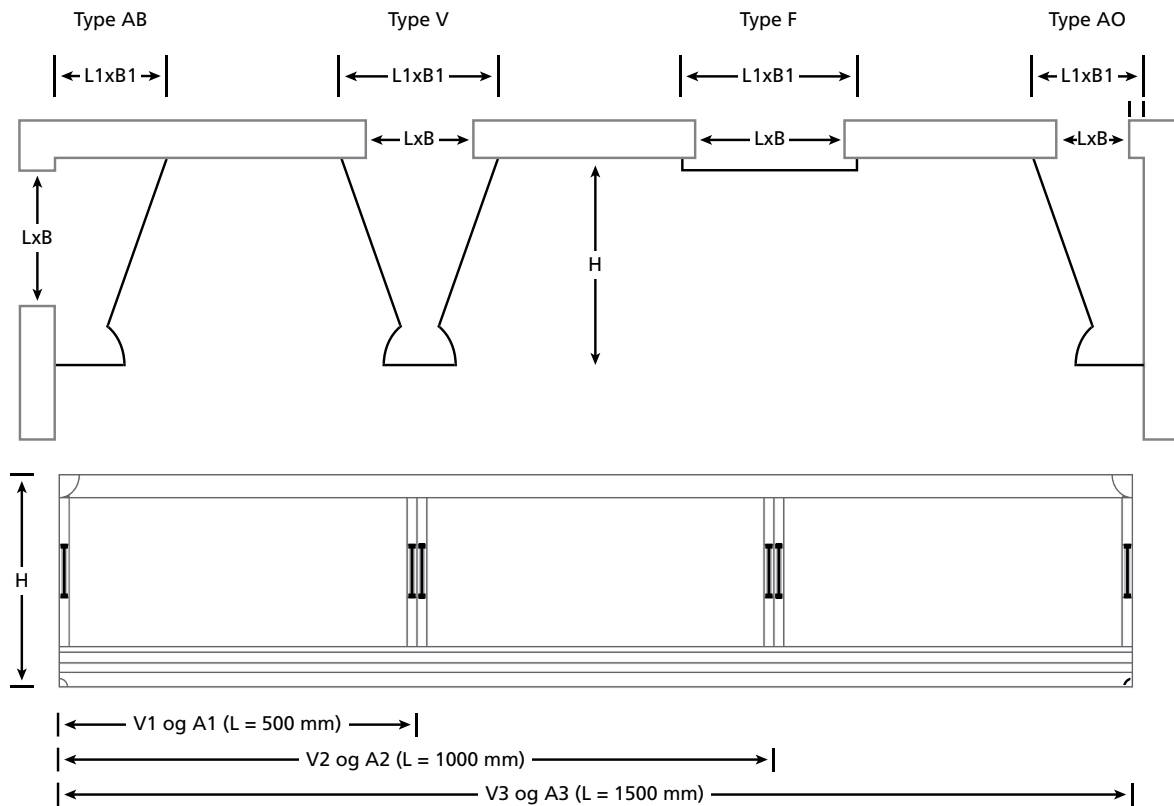

Type	Capacity m ³ /h	Number of cells	External dimensions in mm			Cut-out dimensions in mm	
			L1	B1	H	L	B
V-1 50/25	1000	2	500	225	295	445	160
V-2 50/25	2000	4	1000	225	295	940	160
V-3 50/25	3000	6	1500	225	295	1440	160
V-1 50/50	2000	2	500	390	525	445	325
V-2 50/50	4000	4	1000	390	525	940	325
V-3 50/50	6000	6	1500	390	525	1440	325
AB-1 50/25	500	1	500	165	295	465	195
AB-2 50/25	1000	2	1000	165	295	965	195
AB-3 50/25	1500	3	1500	165	295	1465	195
AB-1 50/50	1000	1	500	245	525	465	430
AB-2 50/50	2000	2	1000	245	525	965	430
AB-3 50/50	3000	3	1500	245	525	1465	430
AO-1 50/25	500	1	500	165	295	445	110
AO-2 50/25	1000	2	1000	165	295	940	110
AO-3 50/25	1500	3	1500	165	295	1440	110
AO-1 50/50	1000	1	500	245	525	445	190
AO-2 50/50	2000	2	1000	245	525	940	190
AO-3 50/50	3000	3	1500	245	525	1440	190
F 50/25	500	1	510	250	20	445	215
F 50/50	1000	1	510	500	20	445	465

DIAGRAM



PRESSURE DROP AND SOUND

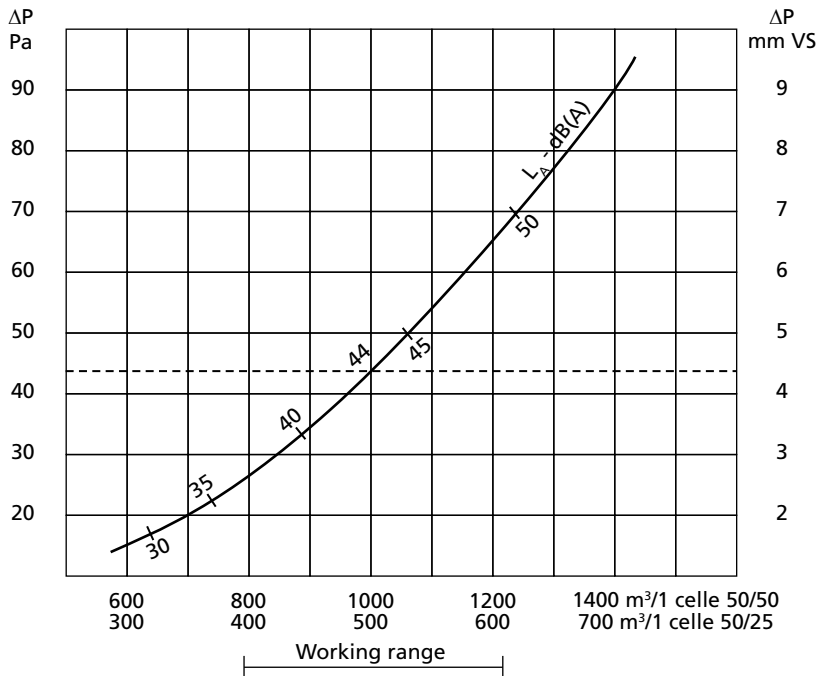

Working range for cells		
Type	Recommended air amount	Filter surface
Celle 50/50	1000 m³/t	0.22 m²
Celle 50/25	500 m³/t	0.11 m²

WEIGHT AND PACKAGING

Type	Packaging dimensions in mm	Weight including packaging
V-1 50/25	300 x 230 x 570	4.0 kg
V-2 50/25	300 x 230 x 1070	8.5 kg
V-3 50/25	300 x 230 x 1570	11.0 kg
V-1 50/50	530 x 400 x 570	7.0 kg
V-2 50/50	530 x 400 x 1070	11.5 kg
V-3 50/50	530 x 400 x 1570	18.0 kg
A-1 50/25	300 x 170 x 570	3.5 kg
A-2 50/25	300 x 170 x 1070	6.5 kg
A-3 50/25	300 x 170 x 1570	9.0 kg
A-1 50/50	530 x 250 x 570	6.0 kg
A-2 50/50	530 x 250 x 1070	9.0 kg
A-3 50/50	530 x 250 x 1570	14.0 kg